

bürkert
FLUID CONTROL SYSTEMS

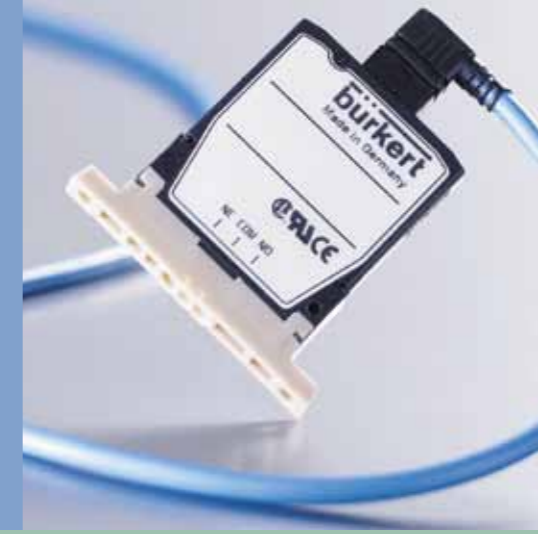

bürkert
FLUID CONTROL SYSTEMS

Product Overview MicroFluidics

Bürkert Fluid Control Systems
Christian-Bürkert-Straße 13-17
74653 Ingelfingen
Germany
Tel. +49 (0) 7940/10-0
Fax +49 (0) 7940/10-91 204
info@burkert.com
www.burkert.com

01 SOLENOID VALVES

02 PROCESS VALVES

03 PNEUMATICS

04 SENSORS

05

06 MASS FLOW CONTROLLERS

07 SOLENOID CONTROL VALVES



Content

3	Introduction
4	Fascination Bürkert
6	MicroFluidics Characteristics
8	Product Technologies
10	Product Overview
14	Fluidic Connection
16	System Competencies
18	Contacts at Bürkert

Introduction

In the pharmaceutical and chemical industries, biotechnology and biomedical engineering, the general trend towards the automatization of procedures is increasingly also accompanied by the miniaturization of the devices involved. This not only allows processes to be designed with considerably greater efficiency, it also opens up whole new fields of application. Bürkert with its particular segment MicroFluidics offers a product line tailored to the needs of this very specific market.

Whether it is for valves, pumps or individual system solutions, the entire product range is geared towards ensuring the controlled handling of even the smallest volumes of liquids. The devices have been designed with the following requirements foremost in mind:

- Miniaturization of the internal and external dimensions
- Modular construction taking the standard structure into account
- Quick, precise and reproducible response times
- High level of dependability
- Low power consumption

The following overview will make your search for the right products easier and is intended to be read as a supplement to the detailed data sheets available at www.burkert.com.

Welcome to the Fascinating World of Fluid Control Systems

Measurement and control: When it comes to working with liquids and gases, we are at your side – as a manufacturer of sophisticated products, as a problem-solver with an eye for the big picture, and as a partner offering you reliable advice. Since we started in 1946, we have developed into one of the world's leading suppliers of Fluid Control Systems. At the same time we have kept our status as a family-owned business with a foundation of strong basic values to highlight the way we think and act.

EXPERIENCE

There are things which are not inherently yours. You have to gather them bit by bit. You receive them from others. And you constantly have to acquire them anew. That is what makes them so valuable. Experience is one of those things. For instance, because of our many years of experience with MicroFluidics, we can provide our extensive services to you – from consulting, development, and 3D CAD simulating to testing and after-sales service. Whether individual product solutions or a pioneering new system for the entire control process: Benefit from our experience.

COURAGE

Those who only work toward optimizing things that already exist will eventually reach the limits – technically, financially, or personally. In order to overcome these limits, courage is needed: The courage to be different and trust one's own ideas; the courage to venture into the unknown, searching for new ways to develop products that have never existed before. We have this courage. By pooling and utilizing our competencies across all sectors, you benefit from our cumulative knowledge of MicroFluidic systems – whether it is in Clinical Diagnostics or Industrial Analytics.

CLOSENESS

Some things we simply take for granted. Only when they are gone, do we realize how important these things really were. This applies in particular to closeness. Without closeness, it is very difficult to build relationships and a good understanding of one another. As an established medium-sized company, we know that. And that is why we are always there for you. Working with you, we develop the best possible solutions for your projects in the area of MicroFluidics. Our global presence in 35 locations enables us to press ahead with technical innovations for our customers around the world.

Bürkert Product Program

We are one of the few suppliers on the market to cover the complete control loop. Our current product range extends from solenoid valves through process and analytical valves to pneumatic actuators and sensors.



Bürkert offers a remarkable range of servo-assisted and direct acting solenoid valves. Read more about them in this brochure.



Bürkert offers unlimited modularity for process control with angle-seat, globe and diaphragm valves in the widest range of configurations.



Here you can find our product range of pneumatic valves, valve units and automation systems as well as information on our control cabinet building.



Here you can find our sensors, transmitters and controllers for measuring and controlling flow, temperature, pressure, level, pH/ORP and conductivity.



The brochure contains an overview of Bürkert miniature valves and micro pumps, which allow for precise and safe handling of small volumes of liquids.

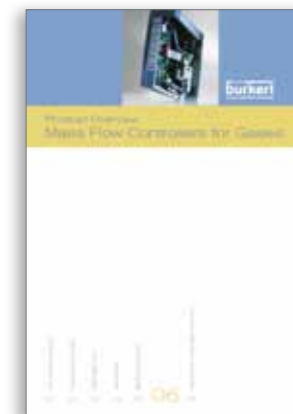

This brochure provides technical background information as well as a detailed product overview for the mass flow controller and meter product range.



This brochure presents our solenoid control valves including their respective features, functions and typical applications.



MicroFluidics Characteristics

With more than 15 years of experience in the field of MicroFluidics, Bürkert is a competent partner of choice when it comes to devising solutions for the handling of even the tiniest volumes of liquids.

In order to meet the special demands derived from miniaturization and the particular area of application, the following criteria all form vital cornerstones in the development of new solutions:



Maximum Precision

In the world of microlitres, precision and exactness are an absolute must. Through innovative solutions and extremely precise manufacturing standards, Bürkert is able to meet the demand for both fast and reproducible response times as well as for long service lives of devices.



Excellent Cleanability

Particularly when handling biological media, cross contamination has to be prevented. Bürkert products offer excellent cleanability thanks to low dead volume design, optimized through-flow, the use of inert materials as well as high-precision moulding.

Low Internal Volume

The more precious the resources are, the more efficiently they should be used. That is why Bürkert pays particular attention to minimizing the internal volume during the development of standard components and individual systems. This not only means that a system's cleanability is improved; it also maximizes the use of fluids flowing through the system.



Outstanding Chemical Resistance

No matter if it is for cell suspensions, acids or highly concentrated solvents, Bürkert has a solution at hand with a broad range of materials for a wide spectrum of applications. Our chemical laboratory works with application specialists and machine tool experts to guarantee an optimal choice even for critical applications.



Low Heat Transfer into the Medium

In order to avoid uncontrolled heat transfer into the medium, Bürkert rigidly keeps the solenoid and fluid chamber separate from each other. In addition, optionally integrated power-saving electronics can reduce the heat production.

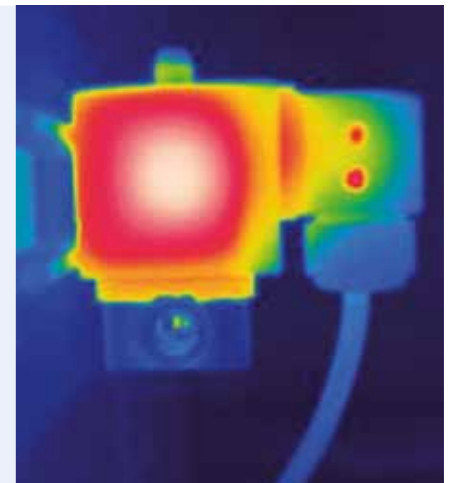

Flipper Valves

The core component in flipper valves is a metal lid vulcanized with elastomer. This pivoting "flipper" is housed in the fluid chamber and alternately closes one of the two valve seats.

As in valves with diaphragms, flipper valves provide a complete separation of medium and actuator. However, the switching action of the flipper creates no pump effect. In addition, the flipper valve technology allows for especially short and reproducible response times and an extended service life due to the lack of diaphragm flexing. This makes

this technology particularly suitable for precise dosing applications. Since the medium does not act on large areas of a diaphragm, flipper valves remain tight even at back pressures above the nominal pressure.

Characteristics:

- short and reproducible response times
- no pulsation
- low power consumption
- enclosed fluid chamber

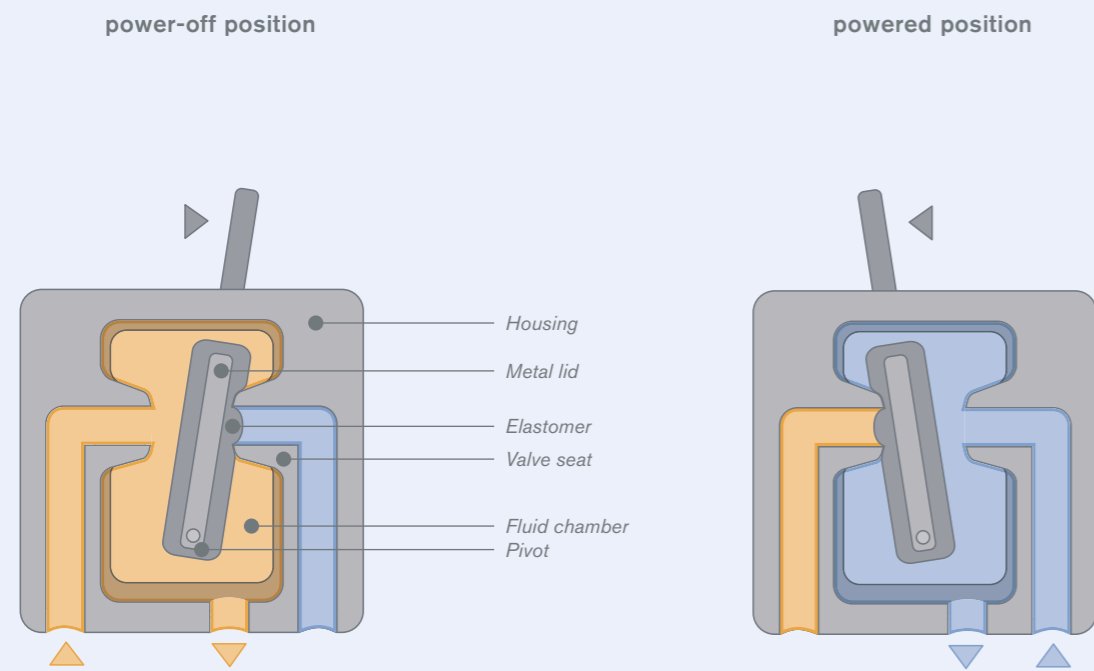

3/2-way valve flipper technology

Rocker Valves

The valve seats in rocker valves are in one plane and opened and closed by a switching rocker. Due to the extremely small amount of moving mass involved, the distinguishing feature of rocker valves is their particularly long service life.

Alongside the non-media-separated valves for pneumatic applications, the principle behind rocker valves also allows for the reliable separation of medium and actuator by way of a diaphragm. In contrast to plunger type valves with a diaphragm, the construction principle of rocker valves provides a secure

seal of the valve seats even if a high back pressure is applied. Due to the lack of gaps in the inner contour and the very good cleanability of the fluid chamber, the media-separated rocker valves are particularly well suited for use with biological media.

Characteristics:

- excellent cleanability
- minimal internal volume
- high back pressure tightness
- media separated from actuator

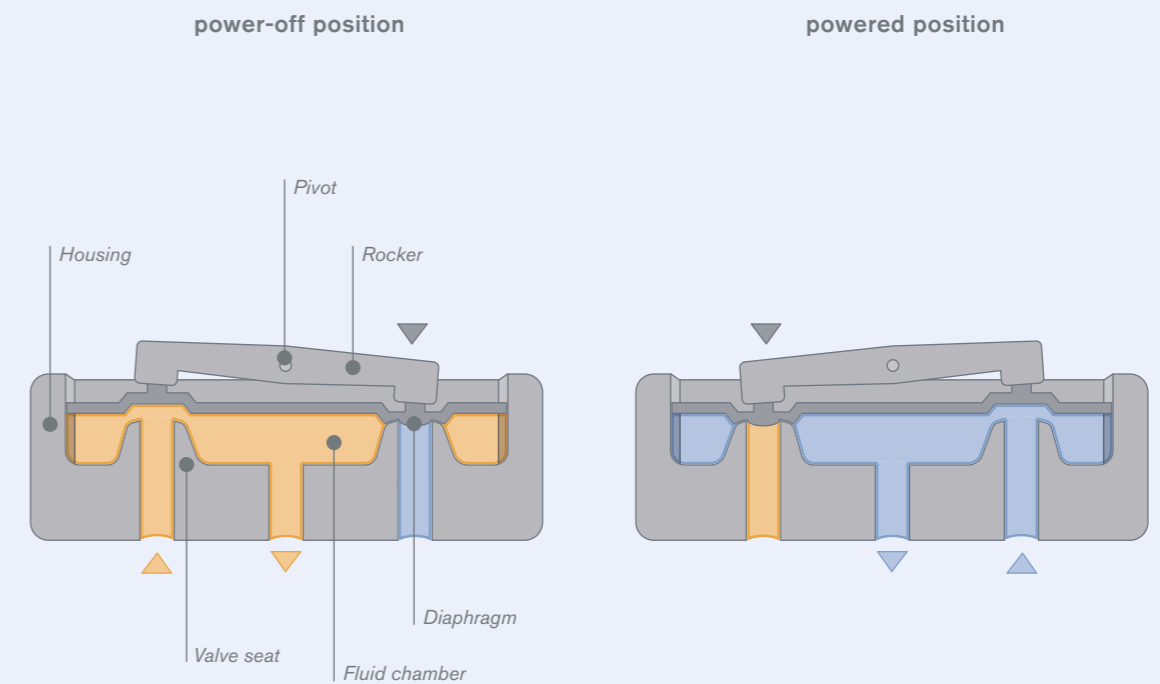

3/2-way valve rocker technology

Valves

Type	Principle		Orifice [mm]	Pressure range [bar] ([psi])	Add-on dimension [mm]	Housing material	Seal material
	Flipper	Rocker					
6650	●		0.4	Vac-7 (101)	4,5	PEEK	FFKM
			0.8	Vac-1 (14)			
6144	●		0.6	Vac-10 (145)	10	PPS	FKM
6604	●		0.6	Vac-3 (43)	10	PEEK	FFKM
			1	Vac-1 (14)			
6627		●	0.8	0-6 (0-87)	16	ETFE, PEEK, PPS, PVDF	EPDM, FFKM, FKM
			1.2	Vac-4 (58)			
			1.6	Vac-3 (43)			
			2.0	Vac-2 (29)			
6106		●	0.9	0-8 (0-116)	16	PA	FKM
			1.2	0-10 (0-145)			
			1.6	Vac-1 (14)			
			2.0	Vac-1 (14)			
6608*	●		2	Vac-10 (145)	22	PEEK	FFKM
			3	Vac-3 (43)			
6128*	●		2	Vac-10 (145)	22	PPS	EPDM, FKM
			3	Vac-3 (43)			
0121	●		2	0-6 (0-87)	32 resp. 35	PP, PTFE, PVC, PVDF, Stainless Steel	EPDM, FFKM, FKM
			4	0-4 (0-58)			
			6	0-2 (0-29)			
			8	0-1 (0-14)			
0124	●		2	0-16 (0-232)	37	PP, PTFE, PVC, PVDF, Stainless Steel	EPDM, FFKM, FKM
			3	0-10 (0-145)			
			4	0-5 (0-72)			
			5	0-4.5 (0-65)			

* Modified flipper principle: seats on one plane.

Detailed technical data can be found on the respective data sheet for each individual type. The chemical resistance

table offers support in selecting the right seal and housing material. All documents are available at www.burkert.com.



Type 6650 – Direct-acting 2/2 or 3/2-way flipper solenoid valve

With a width of just 4.5 mm, type 6650 sets new industry standards. Along with its compact design, the 6650's extremely fast and high-precision switching makes it primarily ideal for use in dosing tasks in the microlitre range. Further advantages of the valve are not least its capability to handle pressures up to 7 bar (101 psi) and a service life of more than 50 million pump cycles.



Type 6144 – Direct-acting 3/2-way flipper solenoid valve

The medium separated type 6144 has been designed for general purpose use and is especially suitable in pneumatic applications. Alongside its compact form, the valve boasts a particularly long service life of more than 500 million cycles and can handle pressures of up to 10 bar (145 psi). It is also available as a latching version or with explosion protection type Ex-ia.



Type 6604 – Direct-acting 2/2 or 3/2-way flipper solenoid valve

The extremely fast and precise switching function in combination with media separation, high media resistance, minimal dead volume design and low internal volume make the 6604 the ideal solution for dosing tasks in analytical and laboratory technology. A latching version is also available.



Type 6627 – Direct-acting 2/2 or 3/2-way rocker solenoid valve

Type 6627 can be even more diversely applied than its now legendary predecessor valve type 127, which still occupies an outstanding place in clinical diagnosis. The valve combines exceptionally low internal volume, inner contours with low dead volume and the excellent cleanability of type 127. In addition, it offers a 2 mm orifice and the option of integrated power-saving electronics.



Type 6106 – Direct-acting 3/2-way rocker solenoid valve

Type 6106 has been designed for pneumatic applications and has the distinguishing features of especially low wear and fast response times. It is also available with explosion protection type Ex-ia.



Types 6128/6608 – Direct-acting 2/2 and 3/2-way flipper valve

The 22 mm wide, media-separated flipper valve is a powerful device for use in analytical applications. Type 6608 uses the materials PEEK and FFKM. Type 6128 comes in PPS/FKM or PPS/EPDM. An orifice of up to 3 mm and a maximum pressure rating up to 10 bar (145 psi) set new benchmarks in plastic valve technology.



Type 0121 – Direct-acting 2/2 or 3/2-way pivoted armature solenoid valve

Type 0121 has been developed especially for use with aggressive chemical substances and waste media. A robust design and high-class materials define the characteristics of this valve.



Type 0124 – Direct-acting 2/2 or 3/2-way pivoted armature solenoid valve

Type 0124 is especially suitable for the control of slightly aggressive chemicals or waste media, which require a separation of medium and actuator. Depending on the orifice, the valve is suitable for pressures up to 16 bar (232 psi), and an orifice of up to 5 mm allows for high flow rates.



Pumps

Type	Flow rate	Frequency input	Pressure	Body material	Sealing material	Self-priming	Inlet/ outlet valves
7604	max. 5 ml/min	max. 40 Hz	max. 0.2 bar	PEEK	FFKM	●	passive
7616	1-5 µl/stroke	max. 15 Hz	max. 2.5 bar	PEEK	FFKM	●	active



Type 7604 – Micro diaphragm pump

The self-priming diaphragm pump is ideal for continuous low flow liquid applications. Since only the high-class materials PEEK and FFKM get in contact with the fluid, the pump can also be used for aggressive chemicals. The mounting pitch of 11 mm allows for an extremely compact design and ease of mounting, with standard bodies designed for surface mount (manifold) or tube connections. The low power consumption of just 1.5 watt means the pump can be easily incorporated into battery-powered mobile devices. The flow rate (max. 5 ml/min) can be adjusted by varying the frequency input to fit the specific performance requirements. Due to the high maximum frequency of 40 Hz, the fluid flows virtually pulsation-free.



Type 7616 – Micro dosing unit

The micro dosing unit 7616 consists of a diaphragm pump and active inlet and outlet valves. The components are assembled on a manifold in order to keep the internal volume to a minimum. The delivered volume can be adjusted via the cycle rate (max. 850 cycles/min) and stroke adjustment (0.5 µl ... 5 µl). Thanks to its high reproducibility (<math>< \pm 2\%</math>), the unit is ideal for precise dosing of the smallest quantities of liquids. PEEK and FFKM are the only materials that come into contact with the media. This facilitates the use with aggressive media. The micro dosing unit can be easily operated via three digital channels. A matching controller, which can be configured via a PC, is also available.

Standard Manifolds

As well as customer-specific manifolds, Bürkert also offers a range of standard solutions for the types 6144, 6604 and 6627. Via a respective common collecting channel, mixer or

distributor functions can be implemented. In addition, the 3-way version also provides a vent.

Suitable valve type	Number of stations	Material	Circuit function	Connection	Features
6144	1-6	Aluminium	3/2-way	M3/M5	with venting channel for pneumatics
6144 and 6604, 11 mm mounting pitch	2-10	PEEK	2/2-way	UNF 1/4-28	all ports in one plane
6627 Standard, 16 mm mounting pitch	2-8	PEEK	2/2-way	UNF 1/4-28	all ports in one plane
6627 High-End, 16 mm mounting pitch	2-8	PEEK	2/2-way	UNF 1/4-28	exceptionally low dead volume, integrated valve seat contour in the manifold, especially suited for vacuums, common port sideways, individual ports on the bottom, delivery comes with valves included.



6 station manifold with valves type 6144



8 station manifold with valves type 6604



6 station manifold with valves type 6627



4 station high-end manifold with integrated valve seat contour for valve type 6627

UNF Flat Bottom Ports

In the MicroFluidics segment, the flat bottom connection with UNF* threads has become the standard connecting technology. Alongside the compact design, this technology in combination with the appropriate fittings offers the following benefits:

- dead volume-free connection
- reliable sealing without additional sealing material or O-rings
- medium only comes into contact with tube and ferrule
- simple assembly without tools
- repeatable disconnection and reconnection

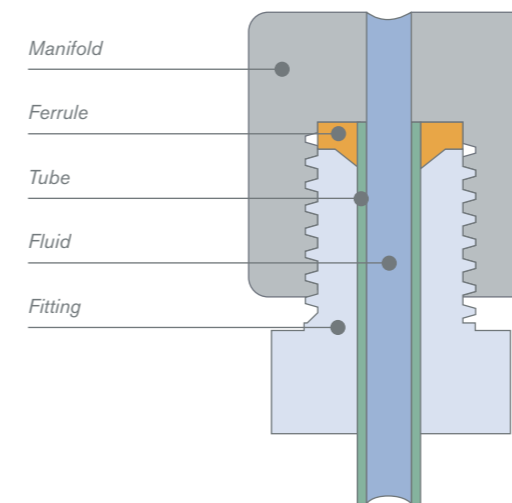

For the common connection size UNF 1/4-28, Bürkert offers standard devices and customer-specific solutions together with the appropriate fittings, ferrules and tubes.

* Unified Fine Thread in accordance with ASME/ANSI B1.10M - 2004

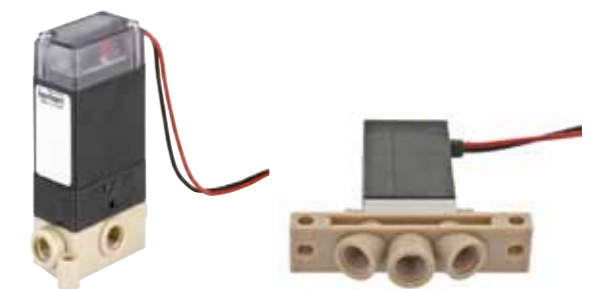

UNF Manifolds

Version		PP	PPS	PEEK	ETFE	PTFE
Fitting standard: 1/8" and 1/16"		•	•	•		
Fitting short version: 1/8" and 1/16"		•	•	•		
Ferrule 1/8" and 1/16"					•	
Tube 1/16": 1.6 mm x 0.8 mm / 1.6 mm x 1.0 mm						•
Tube 1/8": 3.2 mm x 1.6 mm						•

System Solutions

Systemhaus crews worldwide with many years of experience in the business of developing systems enable us to develop and implement tailor-made solutions to meet your demands. The engineers and scientists are on hand to offer you competent consultation.

The spectrum of the individual solutions is exceptionally wide and extends from manifolds, injection moulded plastic parts, integration of additional components, electronics, software, specific fluidic interfaces all the way up to the use of customer-specific fieldbus technology.

In this way we can ensure that you receive the perfect solution for your application. The main focus is put on optimization of the fluidics in terms of cleanability, internal volume and minimized dead volume as well as higher integration of functions into the system. Furthermore, through both the geometric dimensions and selected interfaces, the system is guaranteed to suit perfectly into the later field of application.

System	Manifold	Injection moulded parts	Integration of added components	Customer-specific interfaces	Electronics	Software	Fieldbus technology
5-station manifold type 6606 for rinsing cycle	•						
Compact 16-station dosing head type 6650	•						
Seal gas supply for turbomolecular pumps	•			•			
Endoscope, disinfection and leakage test system	•		•	•			
25-station dosing and mixing unit for DNA synthesizer	•			•	•	•	
16-fold precision pressure controller with I ² C-bus	•		•	•	•	•	•
Water supply and conditioning unit in dental chairs	•	•	•				



5-station manifold type 6606 for rinsing cycle

Each manifold is designed according to the individual needs, making it possible to keep internal volume to a minimum as well as allowing for optimal alignment with its later place of application.

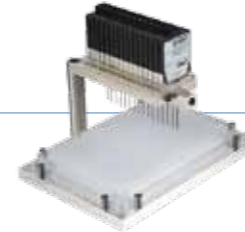

Compact 16-station dosing head type 6650

With a width of 4.5 mm, type 6650 perfectly suits the raster of a 384-well microtiter plate.



Seal gas supply for turbomolecular pumps

The integration into existing systems is made possible through both the individual manifold as well as through customer-specific fluidic interfaces.



Endoscope disinfection and leakage test system

The integration of different components greatly increases the system's functionality.



25-station dosing and mixing unit for DNA synthesizer

Alongside the fluidics, Bürkert can also provide you with the electronics and software to manage the systems.



16-fold precision pressure controller with I²C-bus

For the smooth exchange of data, customer-specific data interfaces can be implemented in addition to the standard fieldbus protocols.



Water supply and conditioning unit in dental chairs

Besides the conventional machining, customer-specific parts can also be manufactured by injection moulding in order to optimize the system from a technical and economical point of view.

Bürkert – Close to You

Germany

Sales Center

Ingelfingen
Bürkert GmbH & Co. KG
Christian-Bürkert-Straße 13-17
DE-74653 Ingelfingen
Tel: +49 (0)7940/10-91 111
Fax: +49 (0)7940/10-91 448
E-mail: info@buerkert.de

Sales Offices

Berlin
Bürkert GmbH & Co. KG
Paradiesstraße 206 b
DE-12526 Berlin
Tel: +49 (0)30/679717-0
Fax: +49 (0)30/679717-66

Hannover

Bürkert GmbH & Co. KG
Rendsburger Straße 18
DE-30659 Hannover
Tel: +49 (0)511/90276-0
Fax: +49 (0)511/90276-66

Dortmund

Bürkert GmbH & Co. KG
Holzener Straße 70
DE-58708 Menden
Tel: +49 (0)2373/9681-0
Fax: +49 (0)2373/9681-50

Frankfurt

Bürkert GmbH & Co. KG
Am Flugplatz 27
DE-63329 Egelsbach
Tel: +49 (0)6103/9414-0
Fax: +49 (0)6103/9414-66

Stuttgart

Bürkert GmbH & Co. KG
Ulmer Straße 4
DE-70771 Leinfelden-Echterdingen
Tel: +49 (0)711/45110-0
Fax: +49 (0)711/45110-66

München

Bürkert GmbH & Co. KG
Elsenheimerstraße 47
DE-80687 München
Tel: +49 (0)89/829228-0
Fax: +49 (0)89/829228-50

North and South America

Argentina

Bürkert-Contromatic Argentina S.A.
Uruguay 2602, Centro Uruguay Norte,
P.B. Oficina 1, (B1643EKP) Beccar,
Pcia. de Buenos Aires, ARGENTINA
Tel: +54 (0)11-5648-6350
Fax: +54 (0)11-5648-6355
E-mail: contacto.argentina@buerkert.com

Brazil

Bürkert-Contromatic Brasil Ltda.
Rua Américo Brasiliense, 2069
Chacara Santo Antônio
04715-005 São Paulo - SP BRAZIL
Tel: +55 (0)11-2186 1155
Fax: +55 (0)11-2186 1165
E-mail: pedidos.brasil@buerkert.com

Canada

Bürkert Contromatic Inc.
5002 South Service Road
Burlington, Ontario L7L 5Y7, CANADA
Tel: +1 905-632 30 33
Fax: +1 905-632 38 33
E-mail: sales.ca@buerkert.com

USA

BURKERT CONTROMATIC CORP.
2915 Whitehall Park Drive, Suite 100
Charlotte, NC 28273, USA
Tel: +1 704-504 44 40
Fax: +1 949-223 31 98
E-mail: marketing-usa@buerkert.com

Europe

Austria

Bürkert-Contromatic G.m.b.H.
Diefenbachgasse 1-3
AT-1150 Wien
Tel: +43 (0)1-894 13 33
Fax: +43 (0)1-894 13 00
E-mail: info@buerkert.at

Belgium

Bürkert Contromatic NV
Wijnegem Zone 1 "De Hoek"
Bijkhoevelaan 3
BE-2110 Wijnegem
Tel: +32 (0)3-325 89 00
Fax: +32 (0)3-325 61 61
E-mail: BC-B@buerkert.com

Czech Rep.

Bürkert-Contromatic G.m.b.H. organizacni slozka
Krenova 35
CZ-602 00 Brno
Tel: +420 543-25 25 05
Fax: +420 543-25 25 06
E-mail: obchod@buerkert.cz

Denmark

Bürkert-Contromatic A/S
Hørkær 24
DK-2730 Herlev
Tel: +45 44-50 75 00
Fax: +45 44-50 75 75
E-mail: info.dk@buerkert.com

Europe, continued

Finland

Bürkert Oy
Atomitie 5
FI-00370 Helsinki
Tel: +358 (0)207 412 550
Fax: +358 (0)207 412 555
E-mail: sales.fi@buerkert.com

France

BURKERT CONTROMATIC SAS
Rue du Giessen
FR-67220 Triembach au Val
Tel: +33 (0)388-58 91 11
Fax: +33 (0)388-57 20 08
E-mail: burkert.france@buerkert.com

Italy

Bürkert Contromatic Italiana S.p.A.
Centro Direzionale „Colombiolo“
Via Roma, 74
IT-20060 Cassina De' Pecchi (Mi)
Tel: +39 02-959 07 1
Fax: +39 02-959 07 251
E-mail: info@buerkert.it

Netherlands

Bürkert Contromatic BV
Computerweg 9
NL-3542 DP Utrecht
Tel: +31 (0)346-58 10 10
Fax: +31 (0)346-56 37 17
E-mail: info@buerkert.nl

Norway

Bürkert-Contromatic A/S
Hvamstuppen 17
NO-2013 Skjetten
Tel: +47 63-84 44 10
Fax: +47 63-84 44 55
E-mail: info@buerkert.no

Poland

Bürkert-Contromatic GmbH Oddzial w Polsce
Bernardynska street 14 a
PL-02-904 Warszawa
Tel: +48 (0)22-840 60 10
Fax: +48 (0)22-840 60 11
E-mail: buerkert@buerkert.pl

Portugal

Tel: +351 212 898 275
Fax: +351 212 898 276
E-mail: portugal@buerkert.com

Spain

Bürkert Contromatic S.A.
Avda. Barcelona, 40
ES-08970 Sant Joan Despí, Barcelona
Tel: +34 93-477 79 80
Fax: +34 93-477 79 81
E-mail: spain@buerkert.com

Sweden

Bürkert-Contromatic AB
Kattsundsgatan 27
SE-211 26 Malmö
Tel: +46 (0)40-664 51 00
Fax: +46 (0)40-664 51 01
E-mail: info.se@buerkert.com

Switzerland

Bürkert-Contromatic AG Schweiz
Bösch 71
CH-6331 Hünenberg ZG
Tel: +41 (0)41-785 66 66
Fax: +41 (0)41-785 66 33
E-mail: info.ch@buerkert.com

Europe, continued

Turkey

Bürkert Contromatic Akiskan Kontrol
Sistemleri Ticaret A.S.
1203/8 Sok. No.2-E
TR-Yenisehir, Izmir
Tel: +90 (0)232-459 53 95
Fax: +90 (0)232-459 76 94
E-mail: burkert@superonline.com

United Kingdom

Bürkert Contromatic Limited
Brimmscombe Port Business Park
Brimmscombe, Stroud
Glos, GL5 2QQ / UNITED KINGDOM
Tel: +44 (0)1453-731 353
Fax: +44 (0)1453-731 343
E-mail: sales.uk@buerkert.com

Africa

South Africa

Bürkert Contromatic (Proprietary) Limited
233 Albert Amon Road
Millennium Business Park
Meadowdale,
Germiston
(Postal: P.O. Box 26260, East Rand 1462)
SOUTH AFRICA
Tel: +27 (0)11-574 60 00
Fax: +27 (0)11-454 14 77
E-mail: sales.za@buerkert.com

Asia Pacific

Australia

BURKERT CONTROMATIC AUSTRALIA PTY.
LIMITED
15 Columbia Way, Norwest Business Park
Baulkham Hills, NSW 2153, AUSTRALIA
Tel: +61 2 8853 6353
Fax: +61 2 8853 6363
E-mail: sales.au@buerkert.com

Victoria
BURKERT CONTROMATIC AUSTRALIA
PTY. LIMITED
Unit 11/26-30 Howleys Road
Notting Hill Victoria 3168
Tel: 1300 888 868
Fax: 1300 888 076

Queensland
BURKERT CONTROMATIC AUSTRALIA
PTY. LIMITED
Unit 4/43 Sandgate Road
Albion Queensland 4010
Tel: 1300 888 868
Fax: 1300 888 076

Western Australia
BURKERT CONTROMATIC AUSTRALIA
PTY. LIMITED
Unit 8, 1st Floor, 85 Reid Promenade
Joondalup WA 6027
Tel: 1300 888 868
Fax: 1300 888 076

South Australia
BURKERT CONTROMATIC AUSTRALIA
PTY. LIMITED
Innovation House, First Avenue
Mawson Lakes SA 5095
Tel: 1300 888 868
Fax: 1300 888 076

Asia Pacific, continued

China

Bürkert Contromatic (Suzhou), Co., Ltd.
(System House) Unit A5, Suhong Square
No. 81 Suhong West Road
SIP Suzhou P.R. China, 215021
Tel: +86 512 6265 8498
Fax: +86 512 6265 9337

Bürkert Contromatic (Shanghai), Co., Ltd.
(logistic and warehouse for BC China)
Floor 2, block 6, 166 Mingdong Road
Pudong New District
Shanghai 201209, P.R. CHINA
Tel: +86 21-5863 9990
Fax: +86 21-5863 9968
E-mail: info.chn@buerkert.com

Beijing

Bürkert Contromatic (Shanghai), Co., Ltd.
Room A 1708, Luowa Building, No.203
Er Ou Lizezhongyuan, Wangjing,
Chaoyang District
Beijing P.R. China, 100102
Tel: +86 10 6439 9783, 6439 9793
Fax: +86 10 6439 9612

Chengdu

Bürkert Contromatic (Shanghai), Co., Ltd.
B zone, 2nd floor,
DongFangGuangYi office building
Long'an city industrial zone, 2nd section,
East 3rd ring Rd.
Chengdu, China 610051
Tel: +86 28 8425 1434, 8425 1435
Fax: +86 28 8425 1560

Guangzhou

Bürkert Contromatic (Shanghai), Co., Ltd.
Room 1502, Tower 4, Dong Jun Plaza
828 - 836 Dong Feng Road East
Guangzhou P.R. China, 510080
Tel: +86 20 8769 8379, 8767 8703
Fax: +86 20 8767 1131

Shanghai

Bürkert Contromatic (Shanghai), Co., Ltd.
Room 501/502 Xin Gai Nian Mansion
No.39 Wu Zhong Road
Shanghai P.R. China, 200233
Tel: +86 21 6486 51 10
Fax: +86 21 6487 48 15

Suzhou

Bürkert Contromatic (Shanghai), Co., Ltd.
Unit 11-12, 5th Floor, Block A
No.5 Xinghan Street
SIP Suzhou P.R. China, 215021
Tel: +86-512-6265 9881
Fax: +86-512-6265 9882

Hong Kong

Bürkert Contromatic (China/HK) Limited
Unit K, 9/Floor, Kwai Shun Industrial Centre
No. 51-63 Container Port Road
Kwai Chung, N.T., HONG KONG
Tel: +852 2480 1202
Fax: +852 2418 1945
E-mail: info.hkg@buerkert.com

India

Bürkert Contromatic PVT Ltd
Apex Towers, 1st Floor, No. 54 II Main Rd
RA Puram
Chennai 600 028, INDIA
Tel: +91 (0)44-4230 3456
Fax: +91 (0)44-4230 3232
E-mail: sales.in@buerkert.com

Japan

Bürkert Ltd.
Imasu moto asakusa-building
4-9-14 Moto Asakusa, Taito-ku
Tokyo 111-0041, JAPAN
Tel: +81 (0)3-5827-0066
Fax: +81 (0)3-5827-0067
E-mail: info.jp@buerkert.com

Osaka

Bürkert Ltd.
2-8-8-1103 Higashi Nakajima,
Higashi-Yodogawa-ku
Osaka 533-0033, JAPAN
Tel: +81 (0)6-6320-0880
Fax: +81 (0)6-6320-0881

Korea

Bürkert Contromatic Korea Co., Ltd.
C-401, Micro Office Bldg. 554-2
Gasam-Dong, Keumcheon-Gu
Seoul 153-803, KOREA
Tel: +82 (0)2-3462 5592
Fax: +82 (0)2-3462 5594
E-mail: info.kor@buerkert.com

Malaysia

BURKERT CONTROMATIC SINGAPORE PTE LTD
2F-1, Tingkat Kenari 6
Sungai Ara
11960 Penang, MALAYSIA
Tel: +60 (0)4-643 5008
Fax: +60 (0)4-643 7010
E-mail: info.sin@buerkert.com

New Zealand

BURKERT CONTROMATIC NEW ZEALAND
LIMITED
44 Rennie Drive
Airport Oaks, Auckland 2022
NEW ZEALAND
Tel: +64 (0)9-256 77 37
Fax: +64 (0)9-256 77 47
E-mail: sales.nz@buerkert.com

Philippines

BURKERT CONTROMATIC PHILIPPINES, INC.
8467 West Service Road, Km. 14, Sunvalley
South Superhighway, Parañaque City, 1700
Metro Manila, PHILIPPINES
Tel: +63 (0)2-7766071 / 7764384
Fax: +63 (0)2-7764382
E-mail: info.rp@buerkert.com

Singapore

BURKERT CONTROMATIC SINGAPORE PTE LTD
51 Ubi Avenue 1, #03-14
Paya Ubi Industrial Park
Singapore 408933, SINGAPORE
Tel: +65 6844 2233
Fax: +65 6844 3532
E-mail: info.sin@buerkert.com

Taiwan

Bürkert Contromatic Taiwan Ltd.
9 F, No. 32, Chenggong Road, Sec. 1,
Nangang District
Taipei
TAIWAN 115, R.O.C.
Tel: +886 (0)2-2653 7868
Fax: +886 (0)2-2653 7968
E-mail: info.rc@buerkert.com